

| Rev. | Note | Revised By | Appr. By | Appr. Date |
|------|---------|------------|----------|------------|
| 2 | UPDATED | EB | EB | 2019-04-17 |

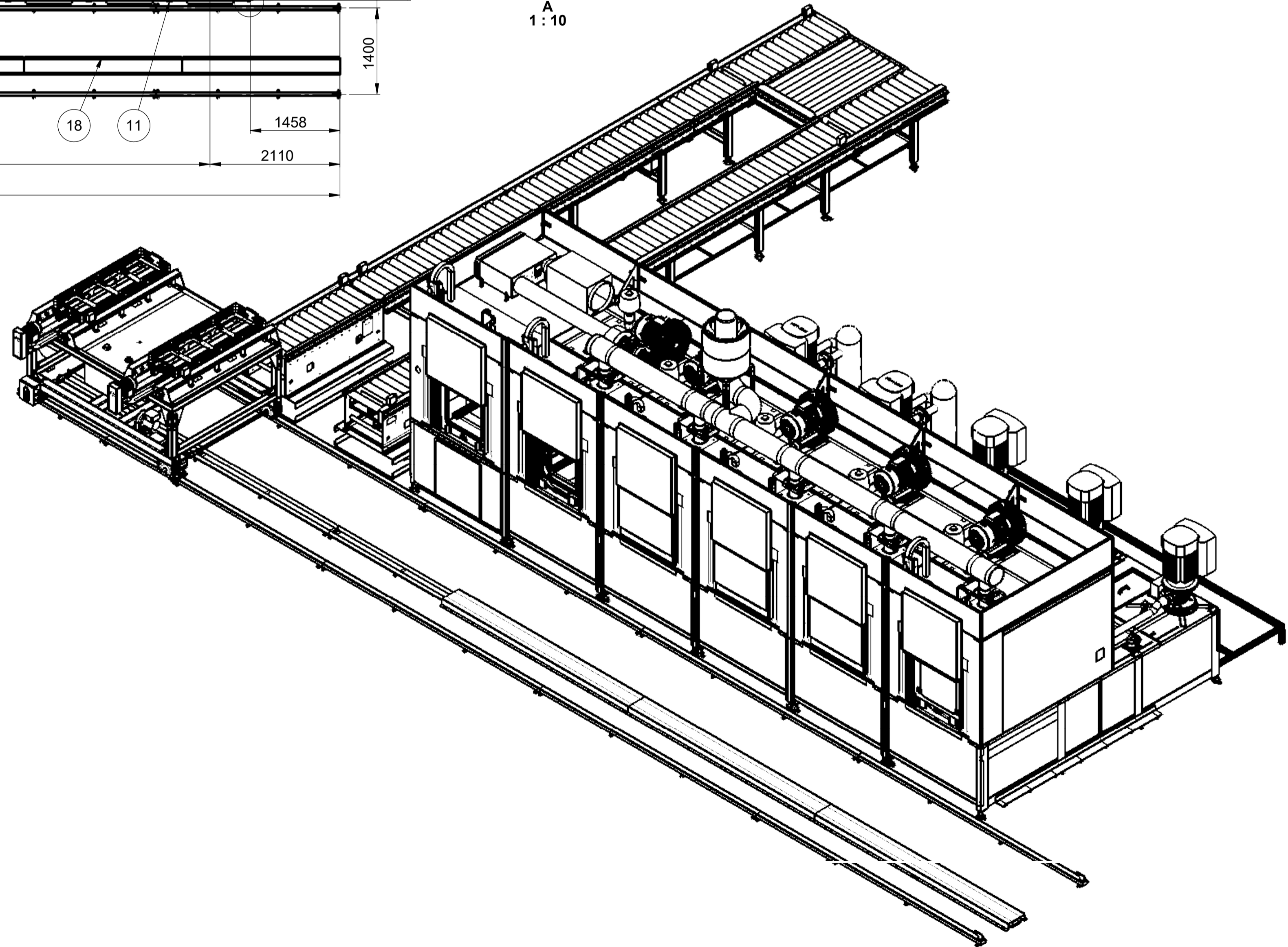
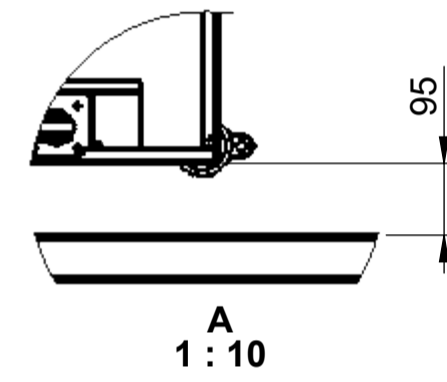
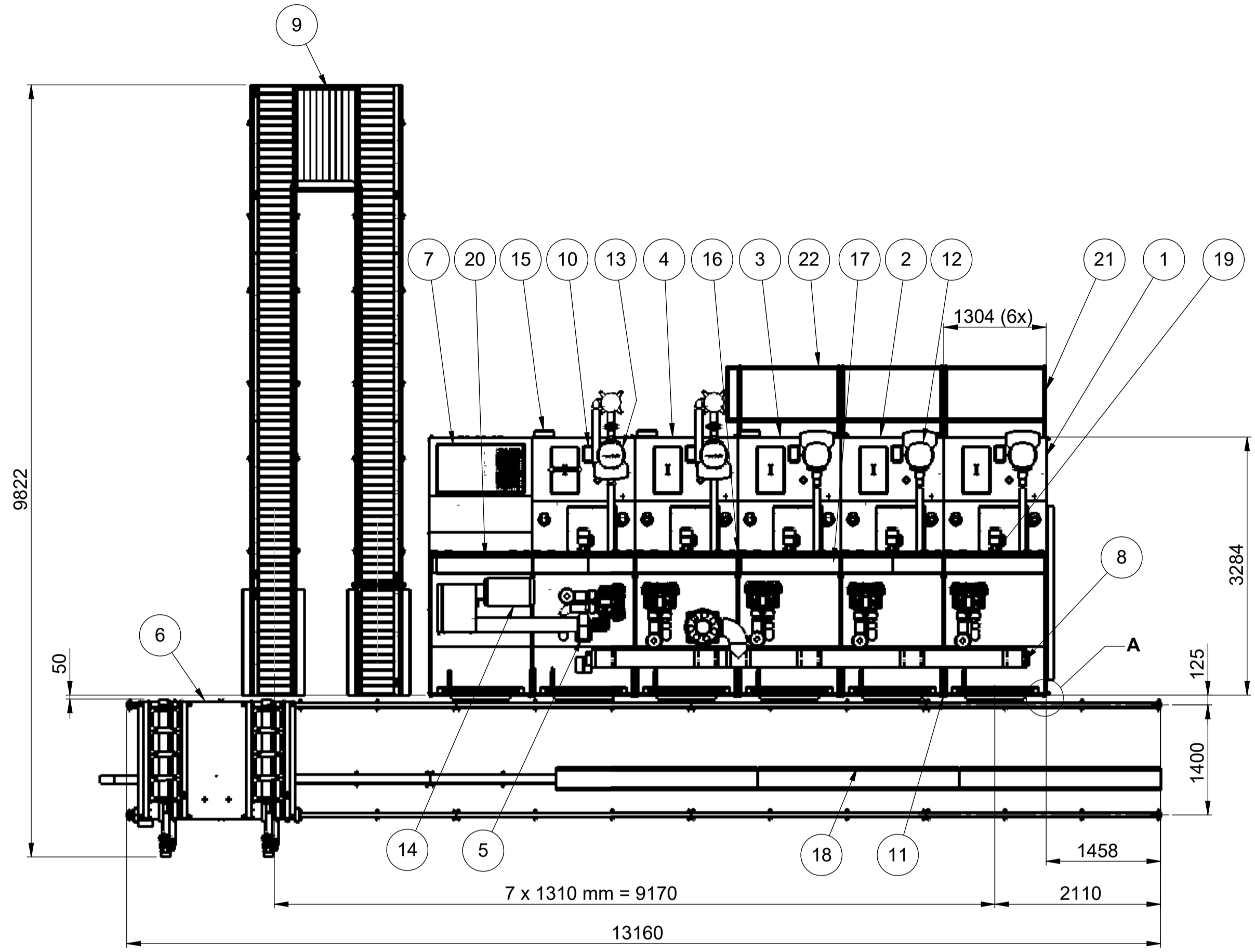
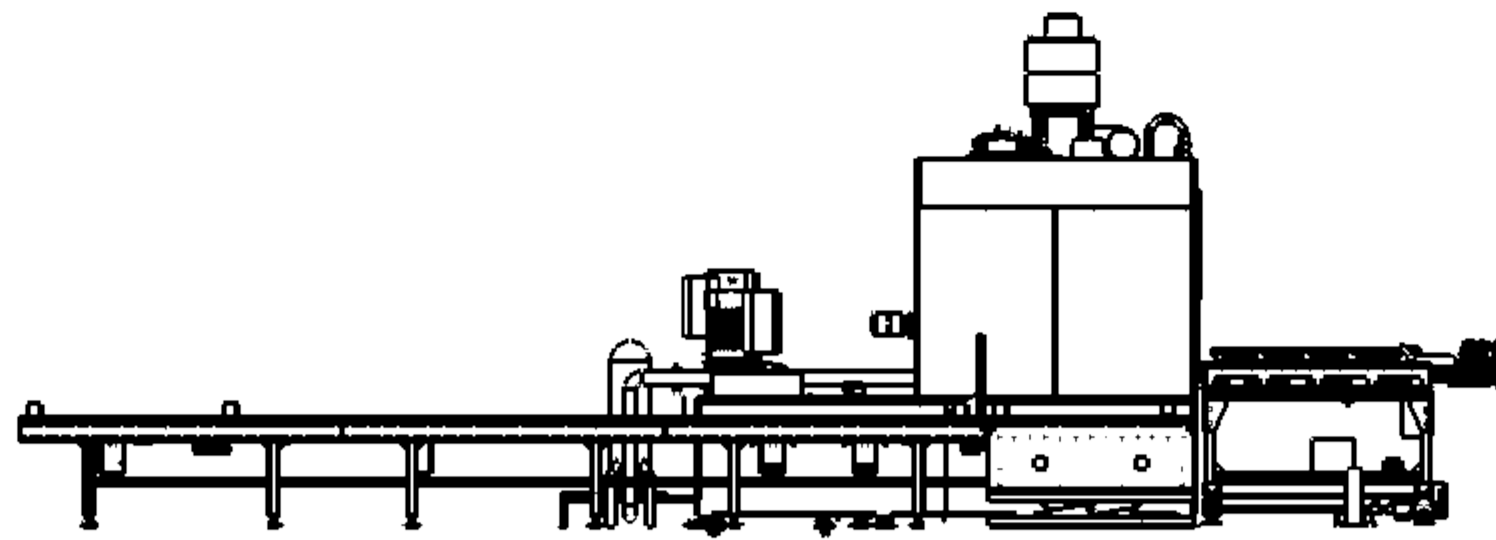
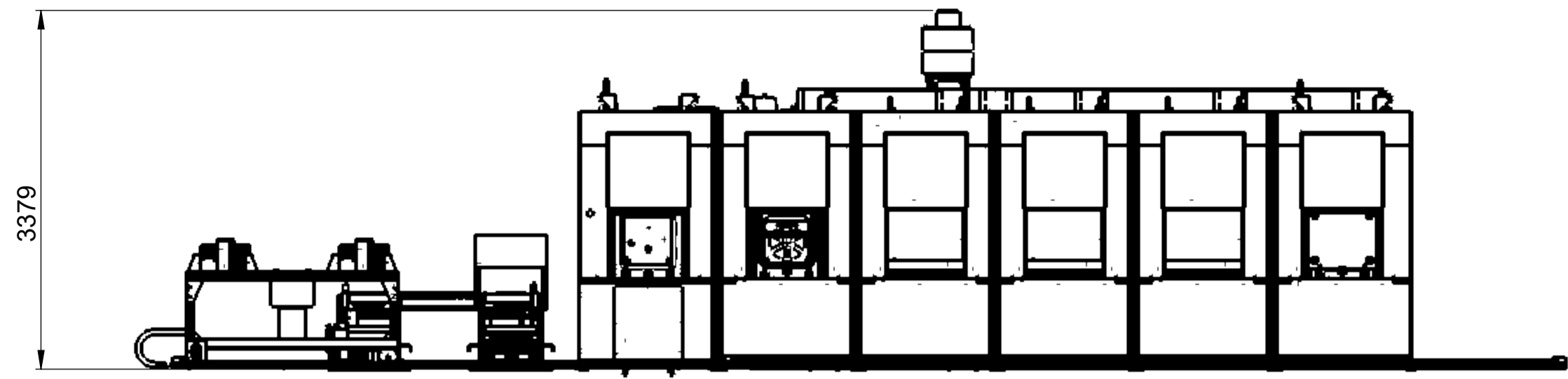

| | |
|------------------------------|------------|
| LAYOUT DRAWING | 1-1415 |
| MACHINE GUARD DRAWING | 1-32885 |
| ELECTRICAL ASSEMBLY DRAWINGS | 4-32731-35 |

| Item No | Ea. | Description | Material | Reference | Remarks |
|---------|-----|---------------------|-----------|-----------|------------|
| 22 | 1 | RAMP | | 62197 | |
| 21 | 2 | RAMP | | 62189 | |
| 20 | 1 | WIRECHANNEL | EN 1.4301 | 200x50 | |
| 19 | 4 | COVER | | 62182 | |
| 18 | 3 | COVER | | 62181 | |
| 17 | 3 | PUMP CASE | | 61060 | |
| 16 | 5 | MOULDING 3 | | 62082 | |
| 15 | 3 | BRACKET | | 62080 | |
| 14 | 1 | AIRCLEANER ASSY. | | 62047 | AHLSSELL |
| 13 | 4 | COVER | | 62046 | Uif. 1. |
| 12 | 6 | COVER | | 62046 | Uif. 2. |
| 11 | 5 | MOULDING 2 | | 62027 | |
| 10 | 5 | OIL RECOVER ASSY. | | | 2D-3-27808 |
| 9 | 1 | ROLLER LINE ASSY | | 60623 | |
| 8 | 1 | MOISTER VENT. ASSY. | | 60932 | |
| 7 | 1 | VACUUM DRYER ASSY. | | 60752 | |
| 6 | 1 | TROLLY ASSY | | 60617 | |
| 5 | 1 | MODULE 5 | | 60858 | |
| 4 | 1 | MODULE 4 | | 60850 | |
| 3 | 1 | MODULE 3 | | 60843 | |
| 2 | 1 | MODULE 2 | | 60856 | |
| 1 | 1 | MODULE 1 | | 60720 | |

| | | | | | | | | | | | | | |
|-------------------------------------|------------|----------------|------|----------------|-----------------|----------|----------|----------------|----------|------------------------------------------------|------|--------------|-----|
| Created | 2016-12-22 | Sign. | ErBo | Tolerance | SS-ISO-2768-1-m | State | Approved | Weight | 14173.57 | Scale | 1:50 | Sheet | 1/1 |
| Appr. | | Heat treatment | | Surface finish | | Material | | Drawing number | 60468 | Rev | 2 | Sheet format | A1 |
| ANMASI Precision Cleaning | | | | | | | | | | ROTOLINE MULTI STAGE 1200x400x300 mm basket | | | |

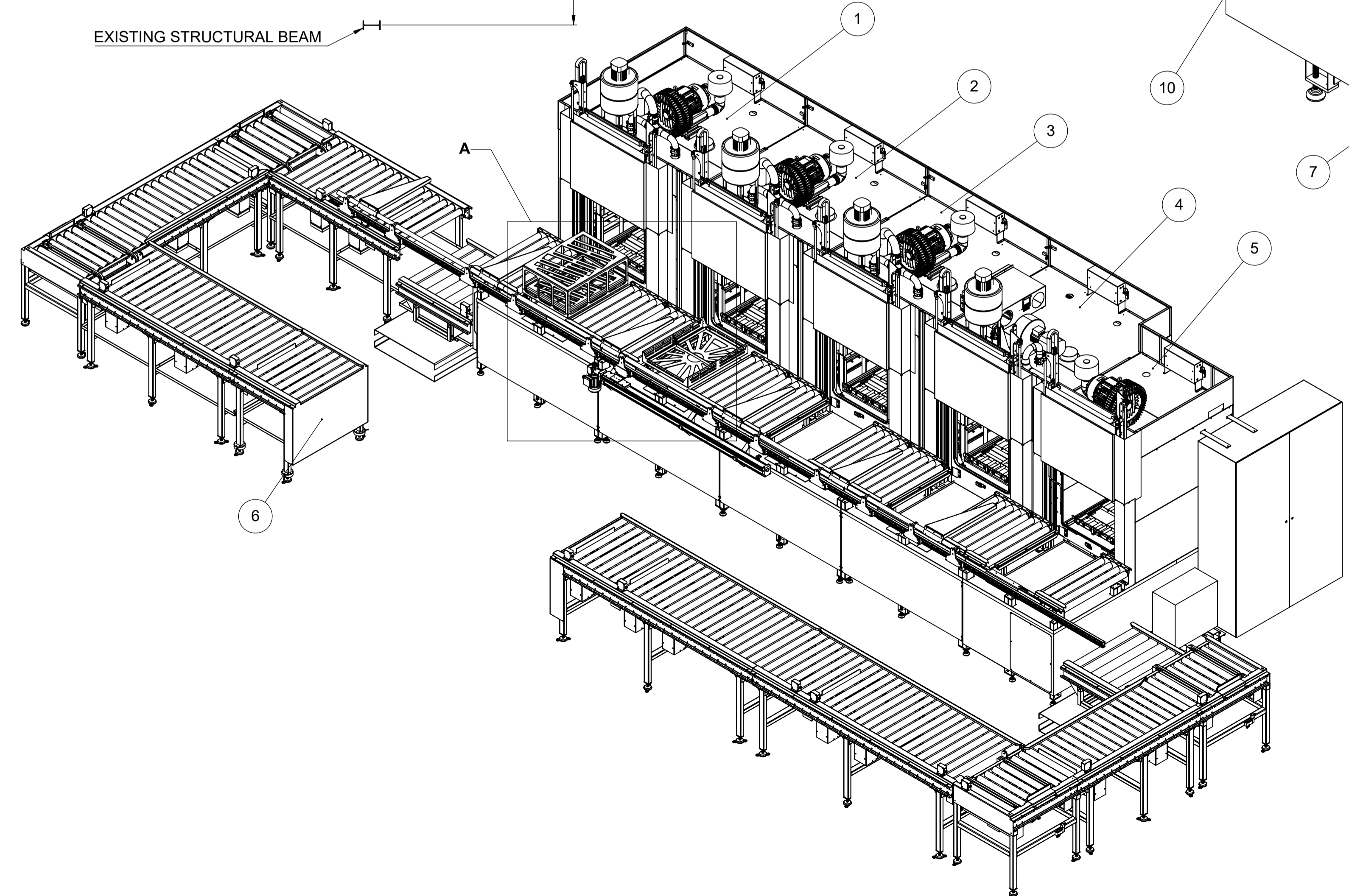
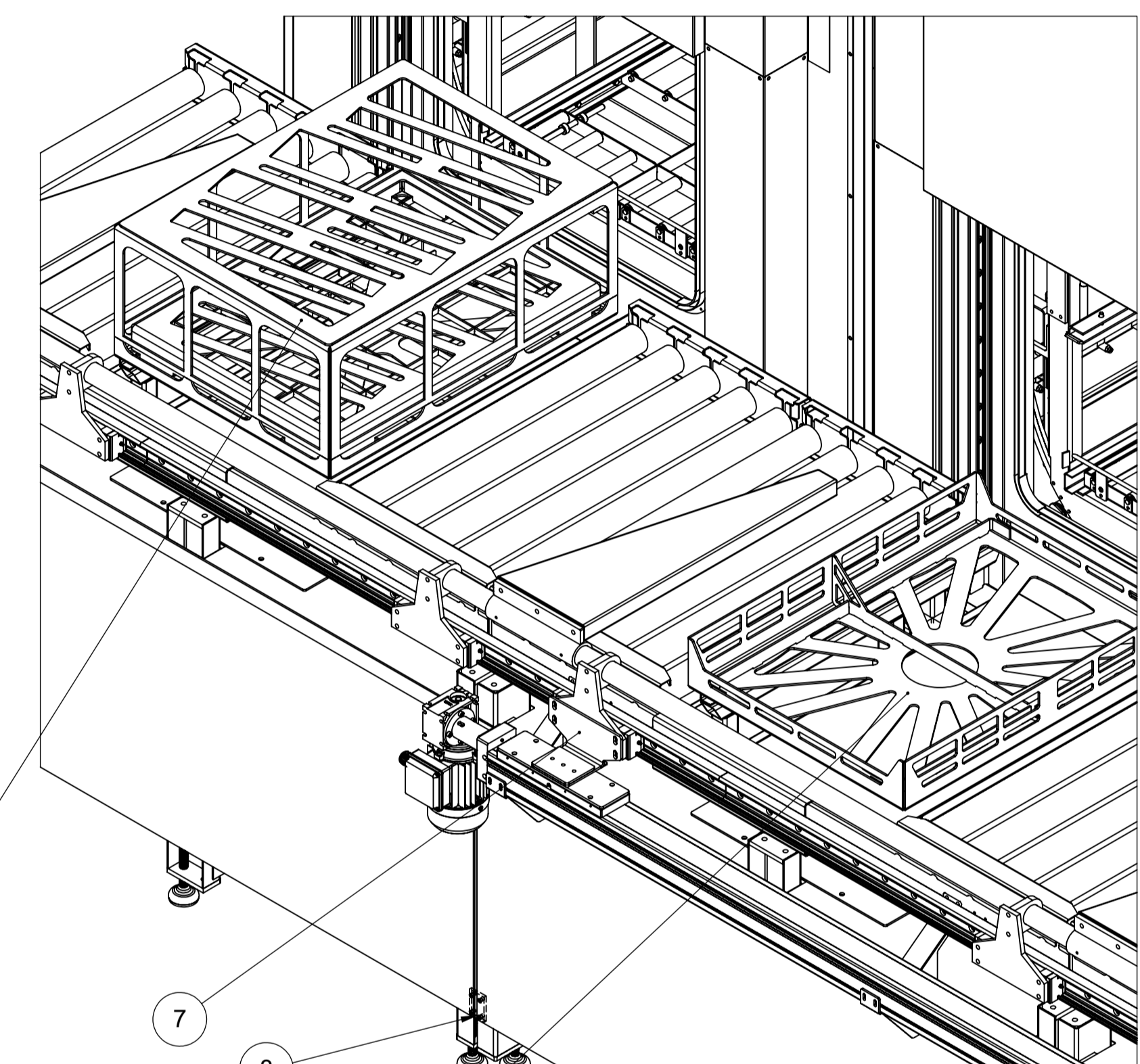
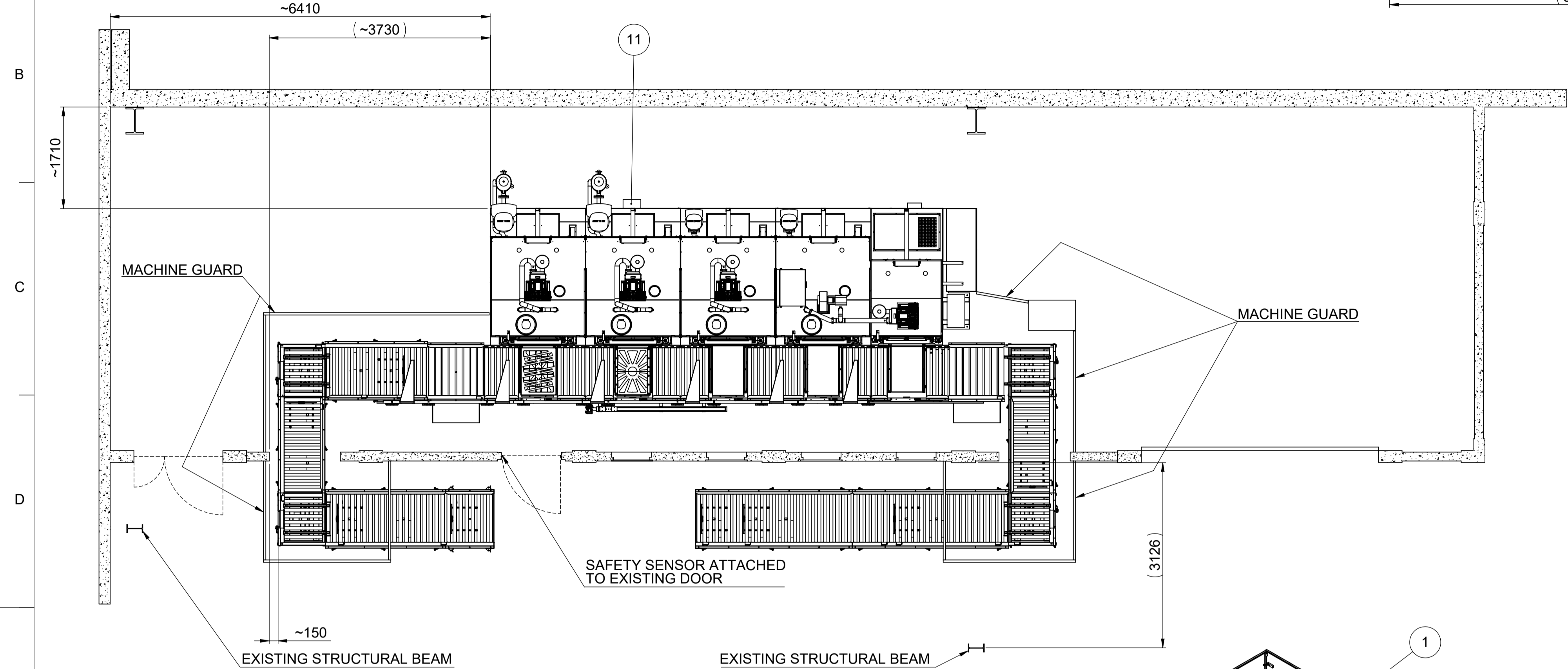
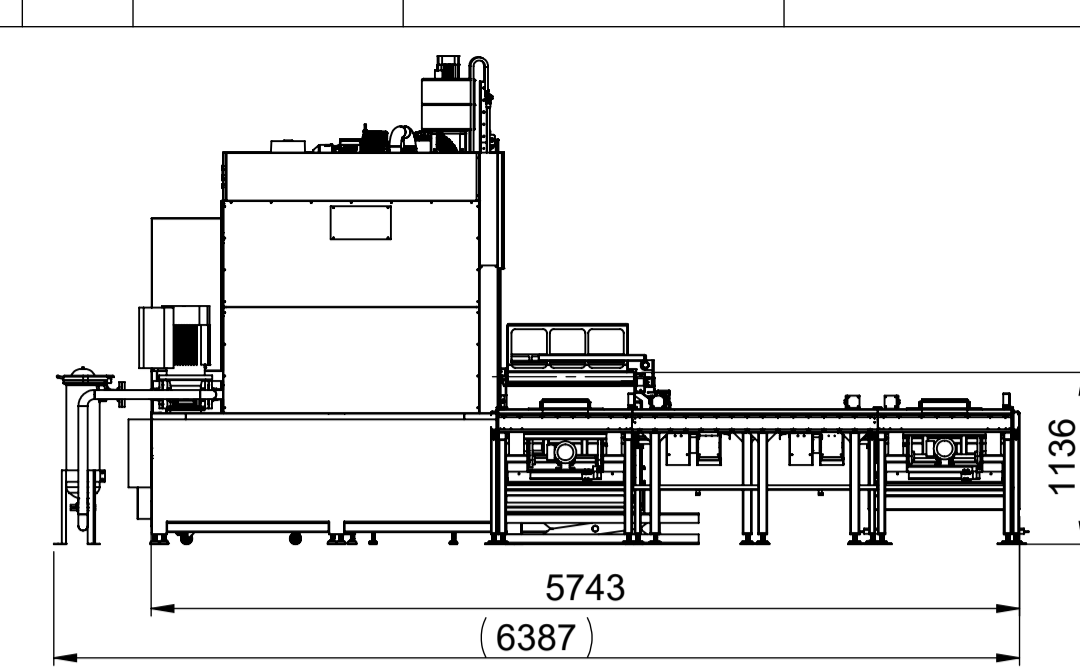
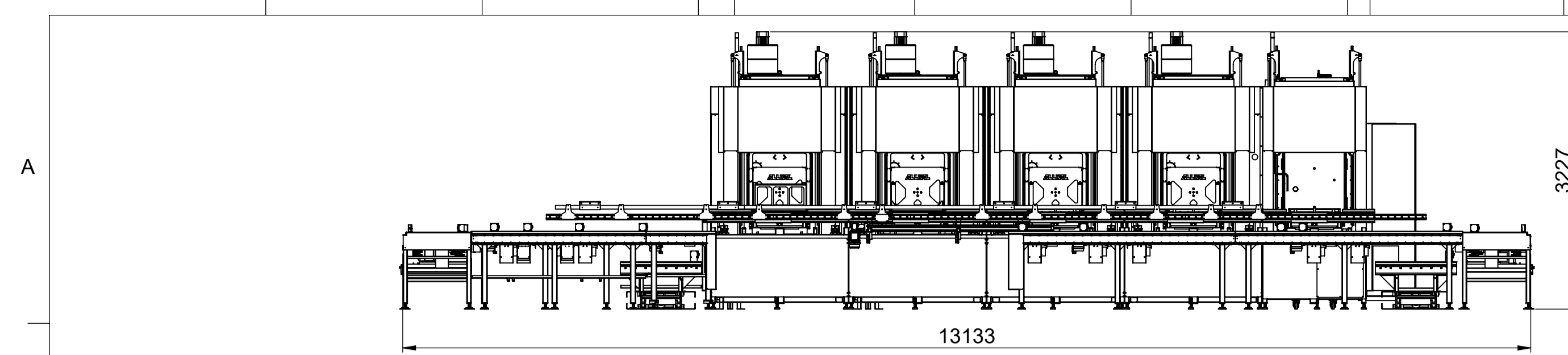

| | |
|------------------------------|-------------|
| LAYOUT DRAWING | 1-1503 |
| MACHINE GUARD DRAWING | 1-33019 |
| ELECTRICAL ASSEMBLY DRAWINGS | 4-32766 -70 |

| Item No | Ea. | Description | Material | Reference | Remarks |
|---------|-----|---------------------|----------|-----------|---------|
| 11 | 1 | OIL SEPARATOR | - | TYPE 211 | BELKI |
| 10 | 12 | MAIN BASKET ASSY | 44793 | | UTF. 2 |
| 9 | 42 | MAIN BASKET 2 ASSY. | 44774 | | UTF. 1 |
| 8 | 8 | PLATE | 44383 | | |
| 7 | 1 | BASKET FEED ASSY | 63049 | | |
| 6 | 1 | ROLLERLINE ASSY | 63048 | | |
| 5 | 1 | VACUUM MODULE ASSY | 63047 | | |
| 4 | 1 | MODULE 4 ASSY | 63046 | | |
| 3 | 1 | MODULE 3 ASSY | 63045 | | |
| 2 | 1 | MODULE 2 ASSY | 63044 | | |
| 1 | 1 | MODULE 1 ASSY | 63043 | | |

| Date | Sign. | Tolerance | Surface treatment | SS-ISO 2768-1 m | State | Approved | Weight | Scale | First angle projection |
|--------------------|-------|----------------|-------------------|-----------------|-------|----------|----------|-------|------------------------|
| Created 2019-04-08 | AS | Surface finish | | | | | 12686.53 | 1:50 | |
| Appr. 2019-04-12 | AS | Heat treatment | | | | | | | |

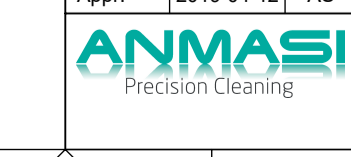

Title/Description: ROTOLINE MULTISTAGE
 800x600x300 mm basket
 Drawing number: 63042
 Sheet: 1/1
 Rev: