

- Description:
1. Flushing pump
  2. Filtration pump
  3. Mixing pump (with mixing nozzles)
  4. Hydrocyclone (optional)
  5. Hydrocyclone (optional)
  6. Filter
  7. Level sensor
  8. Drain manifold
  9. Heating elements
  10. Extraction fan
  11. Panele ultradźwiękowe
  12. Overflow manifold
  13. Flushing pump
  14. Water filling valve 1" DEMI water
  15. Water filling valve 1"
  16. Mixing nozzle in washing stage
  17. Flow manifold
  18. El. cabinet

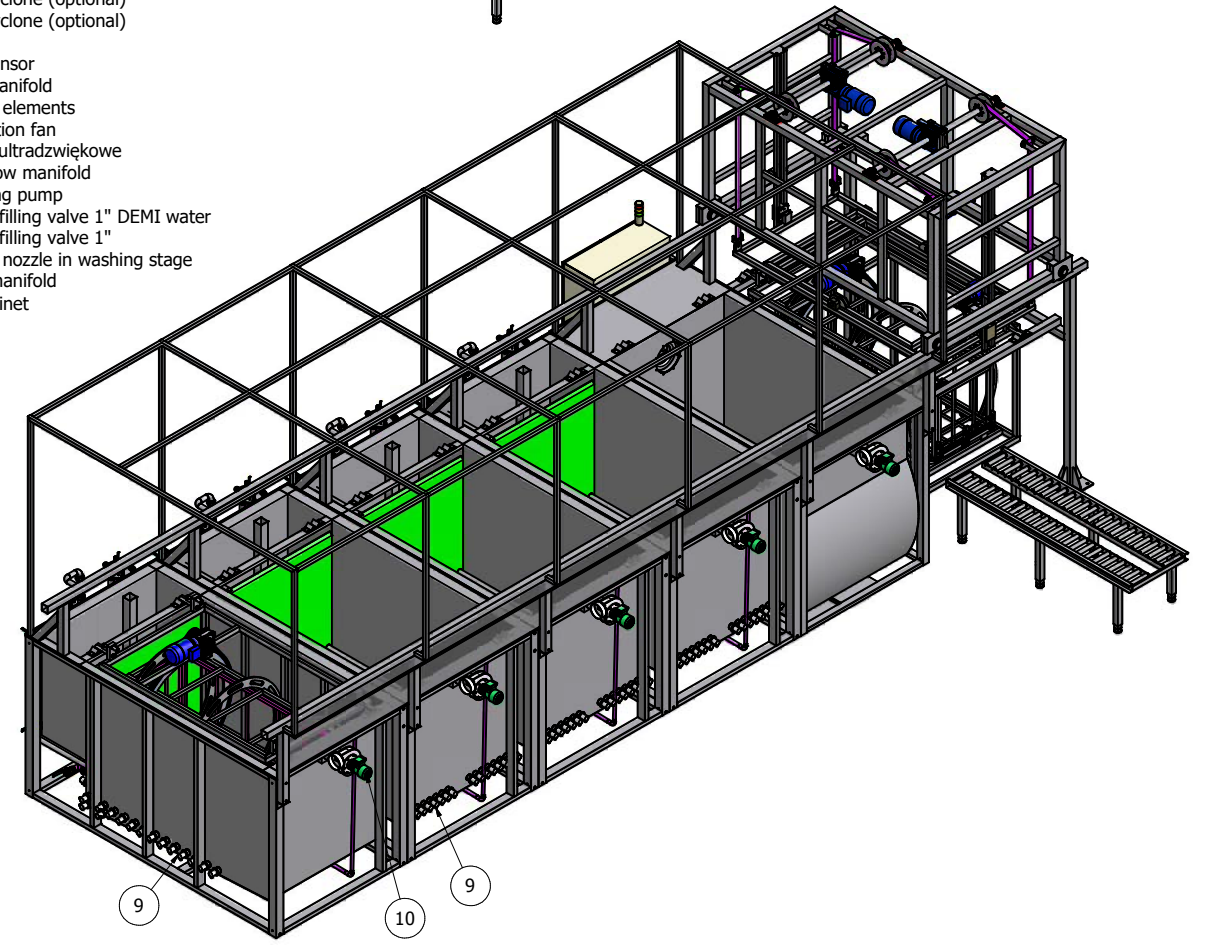

# ANMASI MAXILINE 4-STAGE AUTOMATIC

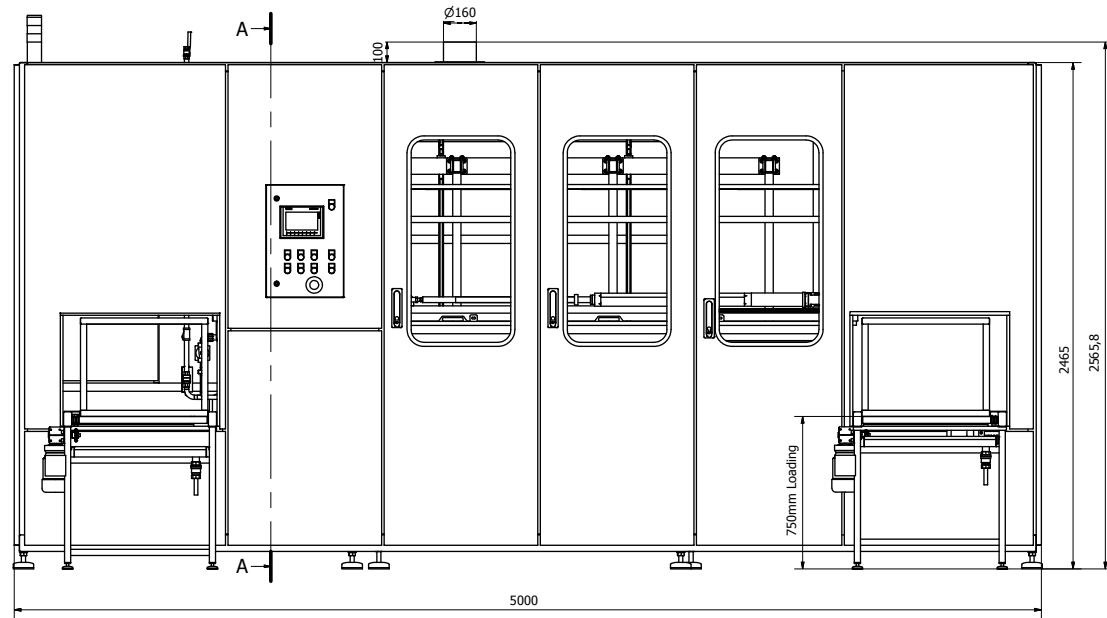

A-A (1 : 13)

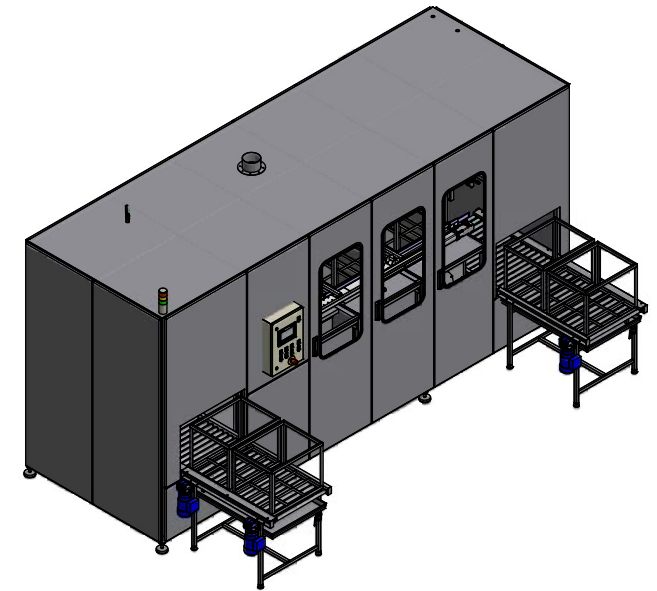
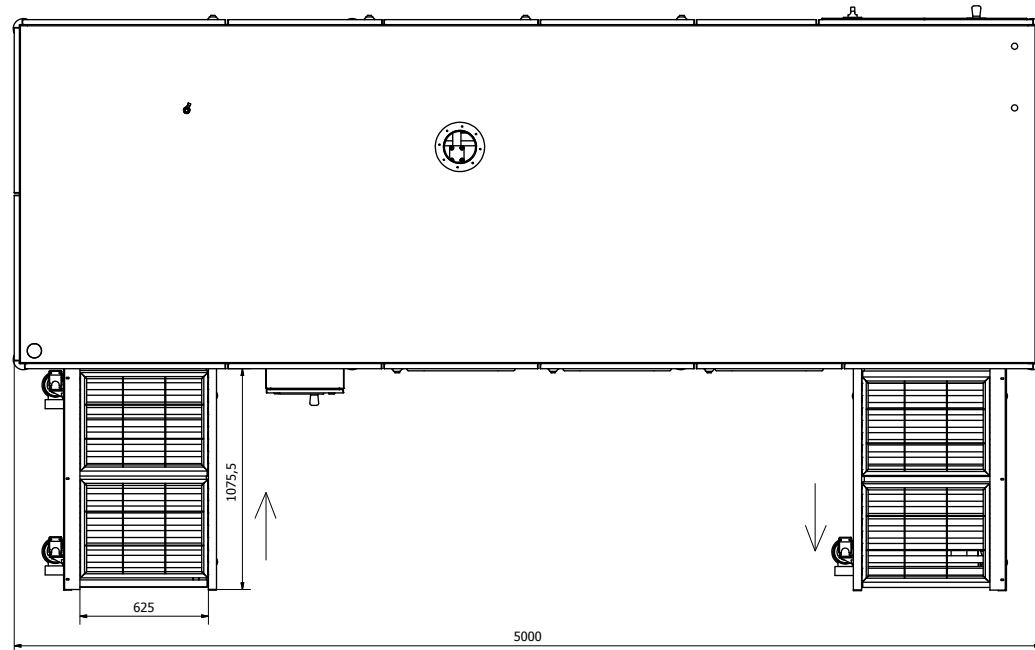
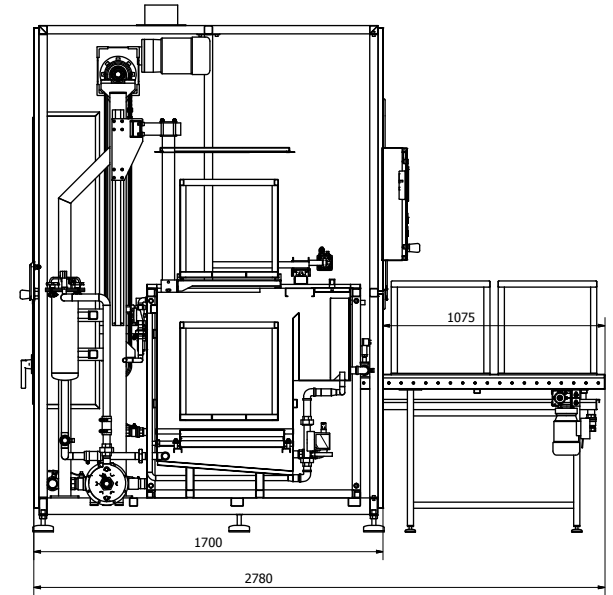



# ANMASI MAXILINE 4-STAGE AUTOMATIC

1. Ultrasonic cleaning
2. Rinsing tank 1
3. Rinsing tank 2
4. Drying
5. Ultrasonic panel
6. Automatic pusher system
7. Level controller
8. Heating
9. Automatic water filling
10. Feeder -dosatron
11. Basket
12. Filter PO4
13. Generator cabinet
14. Elektrikal cabinet
15. Door
16. loading box
17. unloading box
18. Drain collector
19. Pump EBARA CDX HS 70/05
20. Elevator
23. Pump- flushing
24. Oilskimmer
25. DRIP TRAY
26. OPERATOR PANEL PLC

Ultrasonic cleaning U1000  
 (LxBxH) 660x660x570  
 Ultrasonic effect 3000 W  
 Heating effect 8000 W

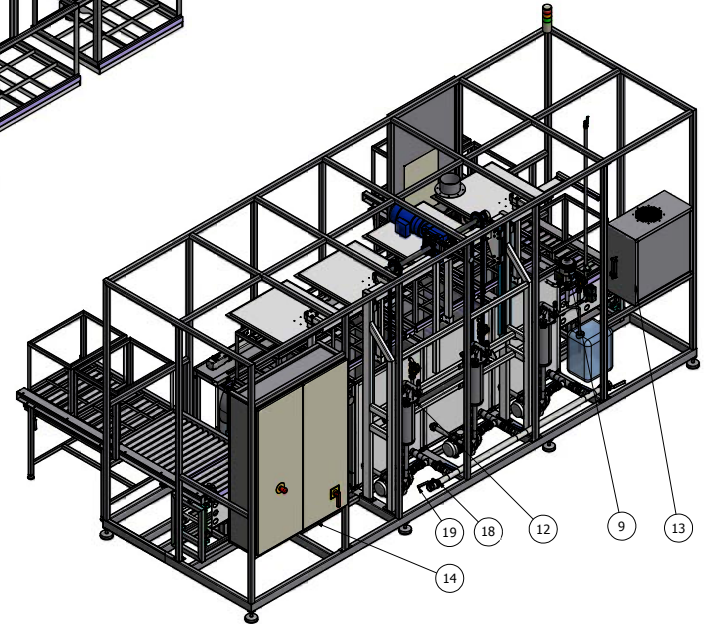
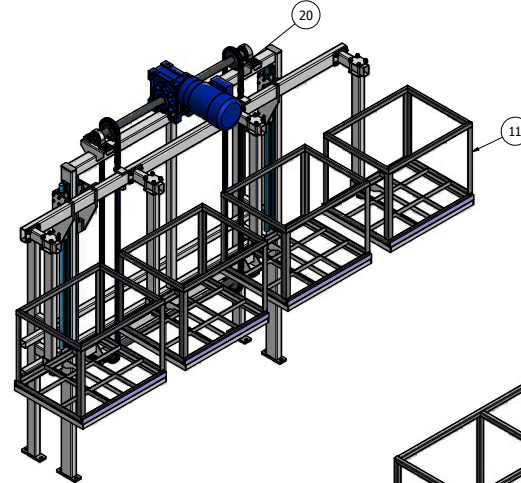
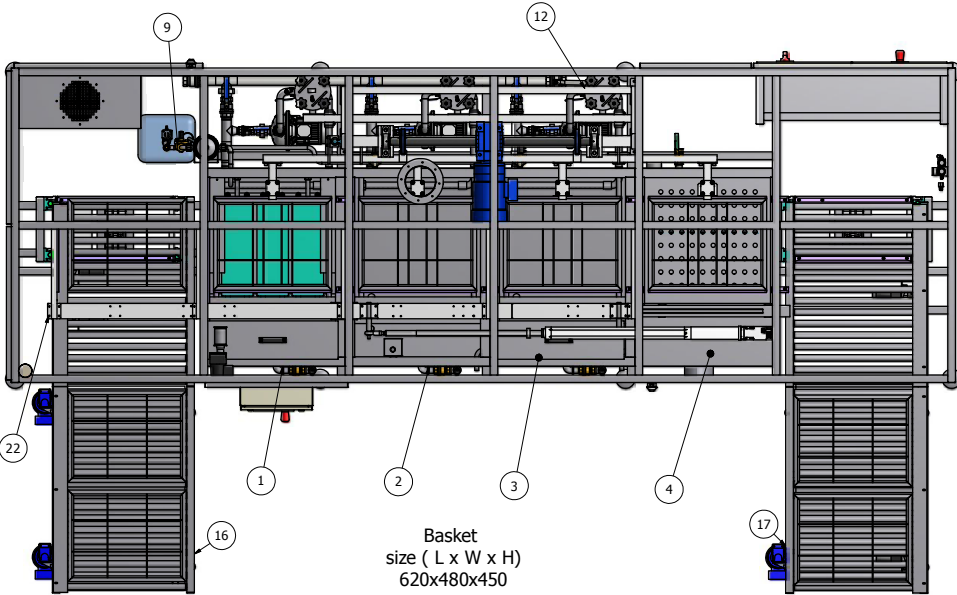
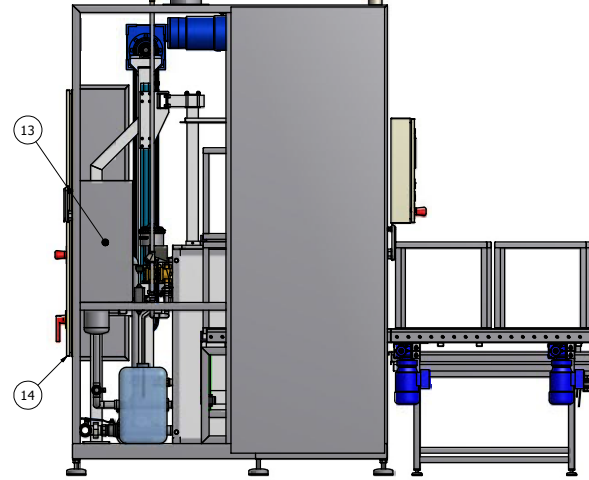
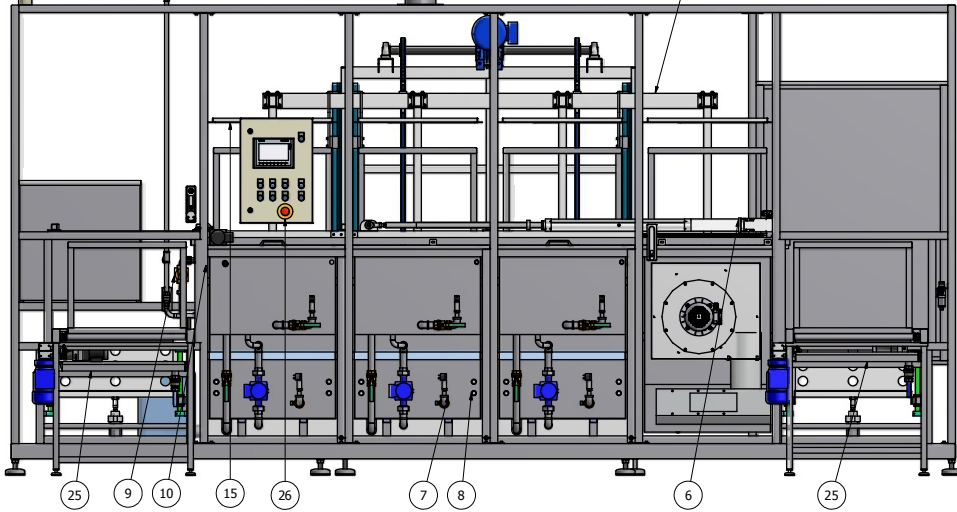

Basket size ( L x W x H )  
 620x480x450

A-A ( 1 : 12 )

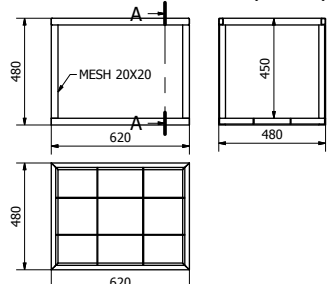

F-F ( 1 : 10 )

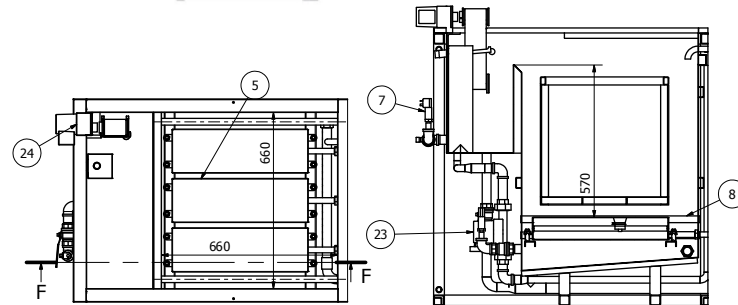

# ANMASI MAXILINE ULTRASONIC CLEANING SYSTEM

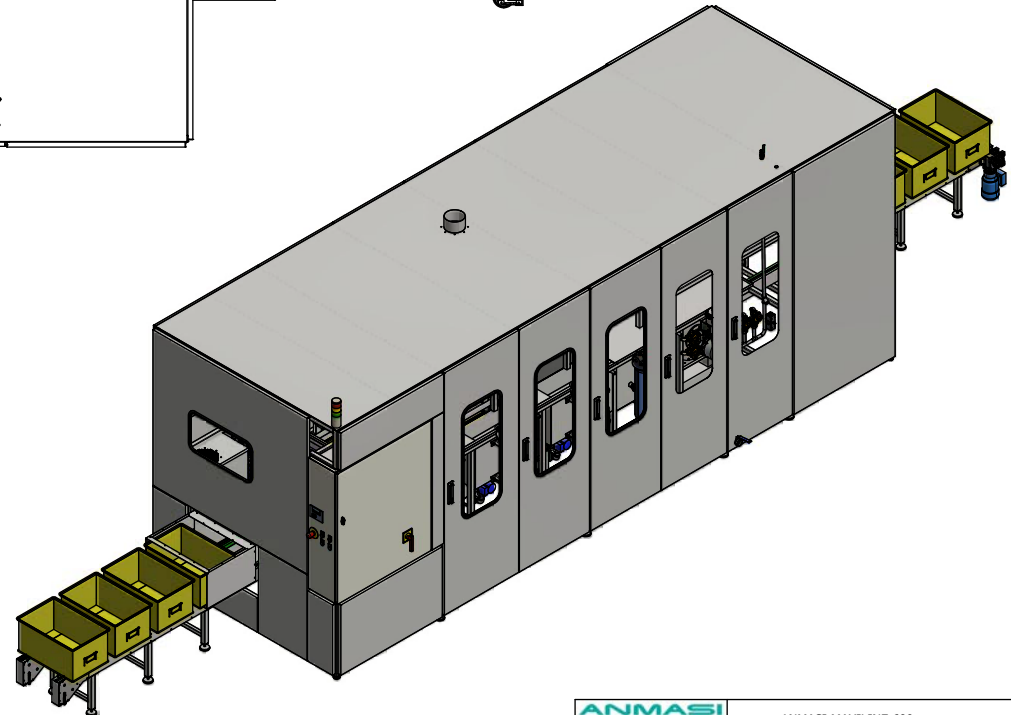
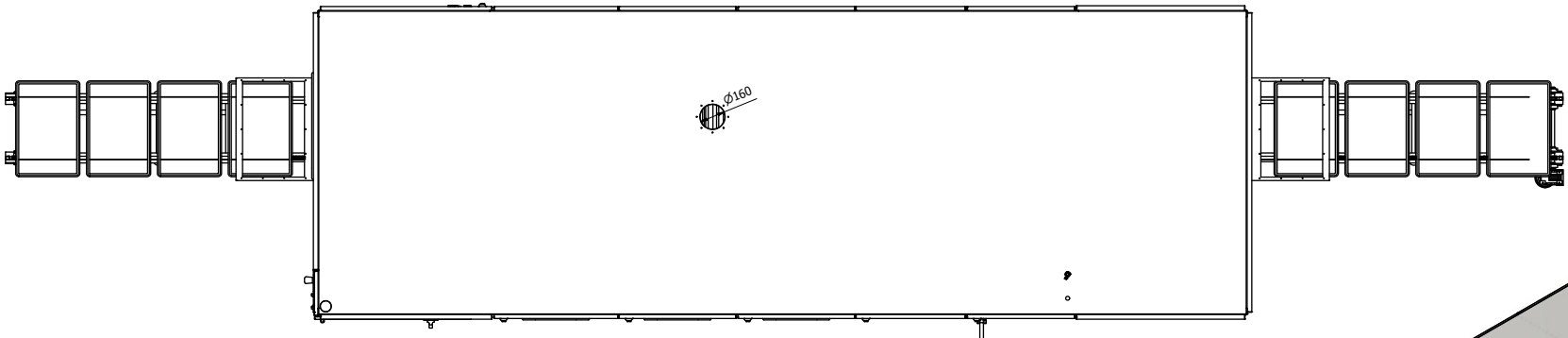
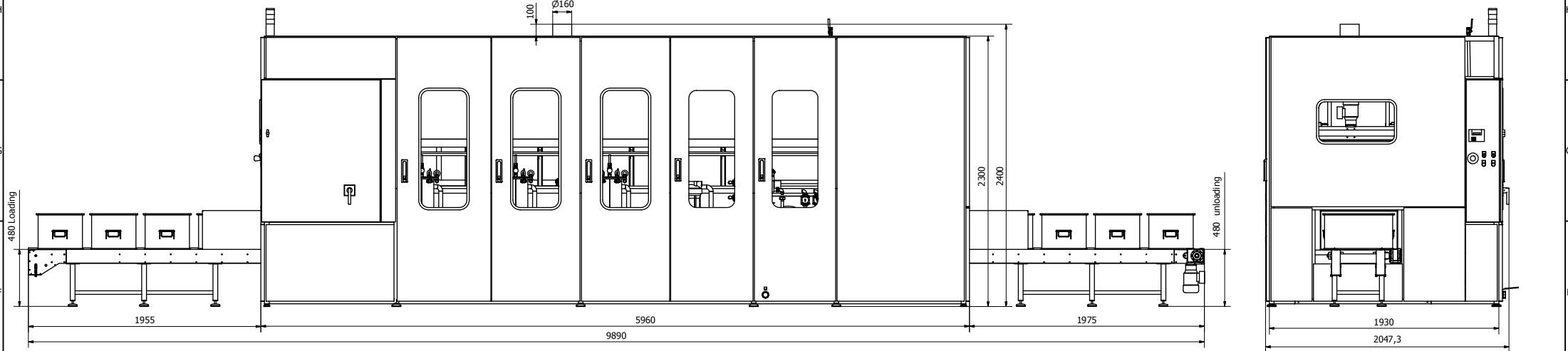

# ANMASI MAXILINE ULTRASONIC SYSTEM

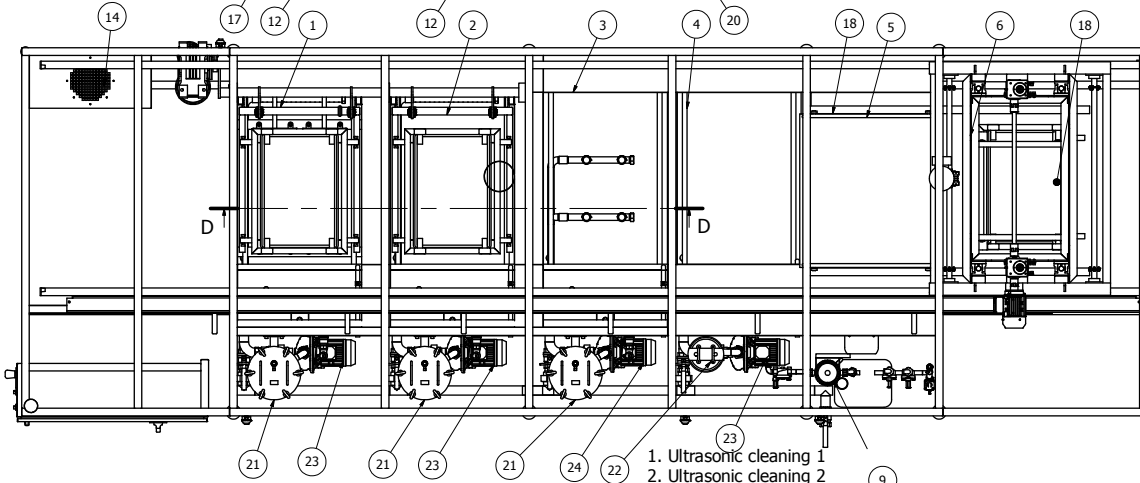
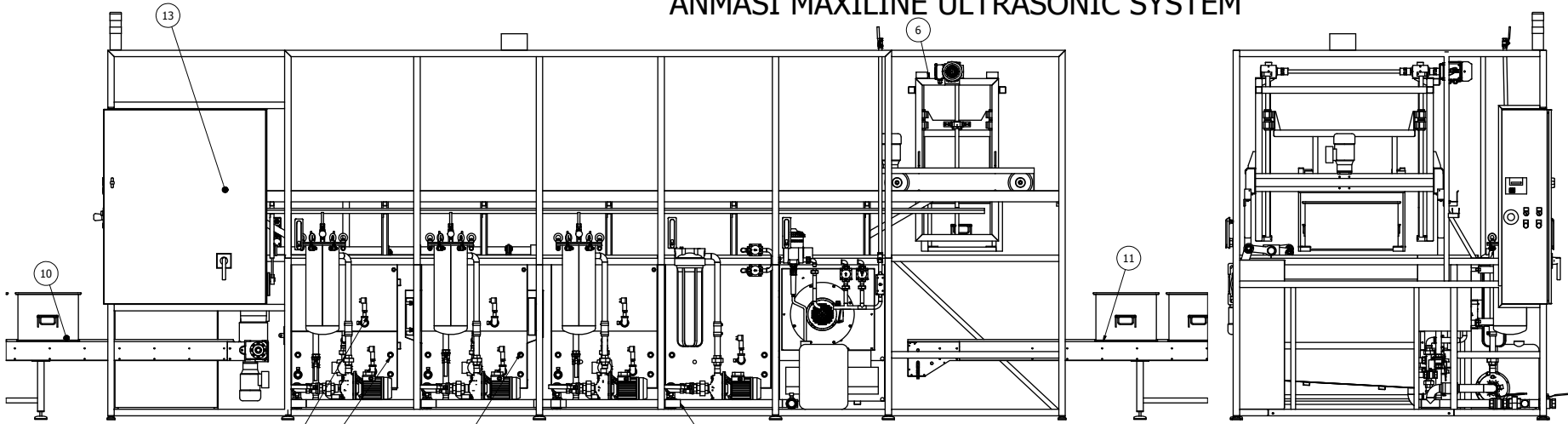

D-D ( 1 : 10 )

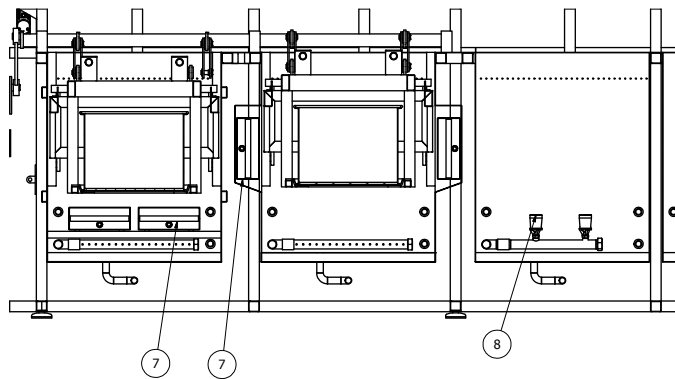

1. Ultrasonic cleaning 1
  2. Ultrasonic cleaning 2
  3. Rinsing tank 1 Venturi
  4. Rinsing tank 2
  5. Drying
  6. Automatic system with agitation
  7. Ultrasonic panel
  8. Venturi
  9. Feeder -dosatron TANK 1+2
- ANMASI SUPPLY
10. Table loading
  11. Table Unloading
  12. Heating
  13. Elektrikal cabinet
  14. Generator cabinet
  15. Transport frame
  16. Basket
  17. Level controler
  18. Pneumatic door drying
  19. Agitation
  20. Drain collector
  21. Filter PO1
  22. Filter 10" ANMASI SUPPLY
  23. Pump EBARA CDX HS 70/05
  24. Pump EBARA CDX HS 200/25

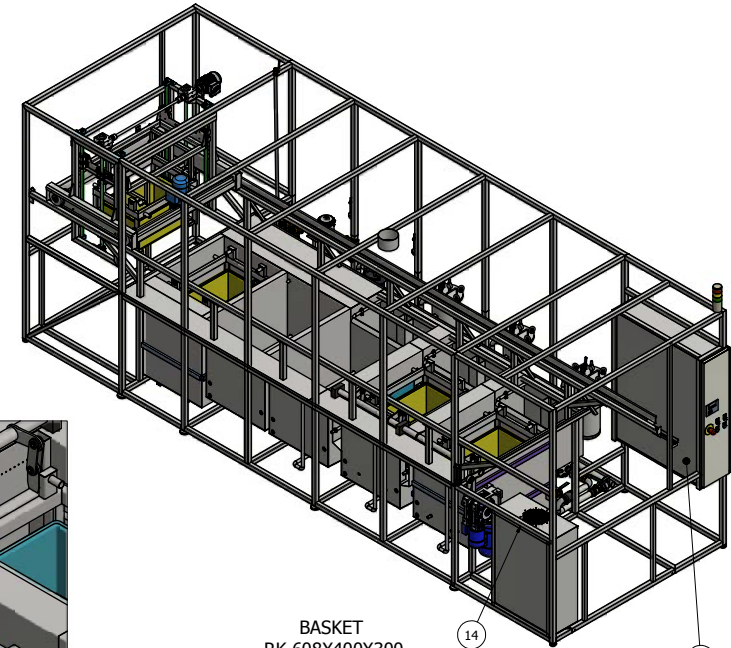
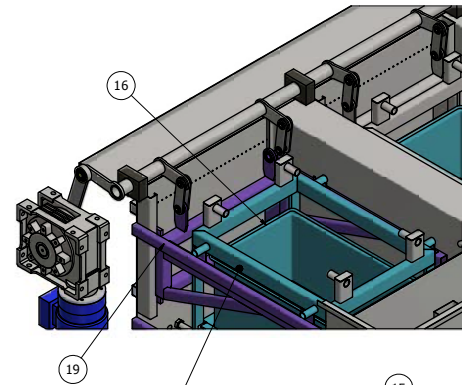

BASKET  
RK 608X400X300

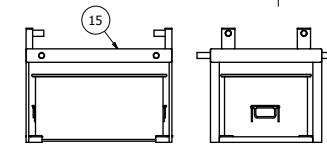
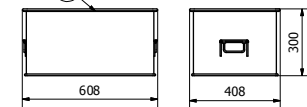

Ultrasonic cleaning U1000  
(LxBxH) 900x650x480  
Ultrasonic effect 4000 W  
25 kHz  
Heating effect 8000 W



ANMASI MAXILINE 600

Order: KO10836  
132/ANM/2018 SN 145/2018 Rev 1 Date